

**Nächste Generation Thermoprozesstechnik
Industriefofensysteme GmbH**



Thermo process technique and industrial furnace systems for the industry

- ACC_CON Technology, forced air circulation
- Temperature 950 °C and 1.300 °C
- Electro heating with controlled sections
- Charge up to 2.000 kg
- Insulation modules or inner brickwork
- Temperature control in the chamber and /or on object

➤ Product group:
Anneali**N.G.T.I.**

- **Standard series furnaces**
- **Custom made furnaces**
- **Special equipment**

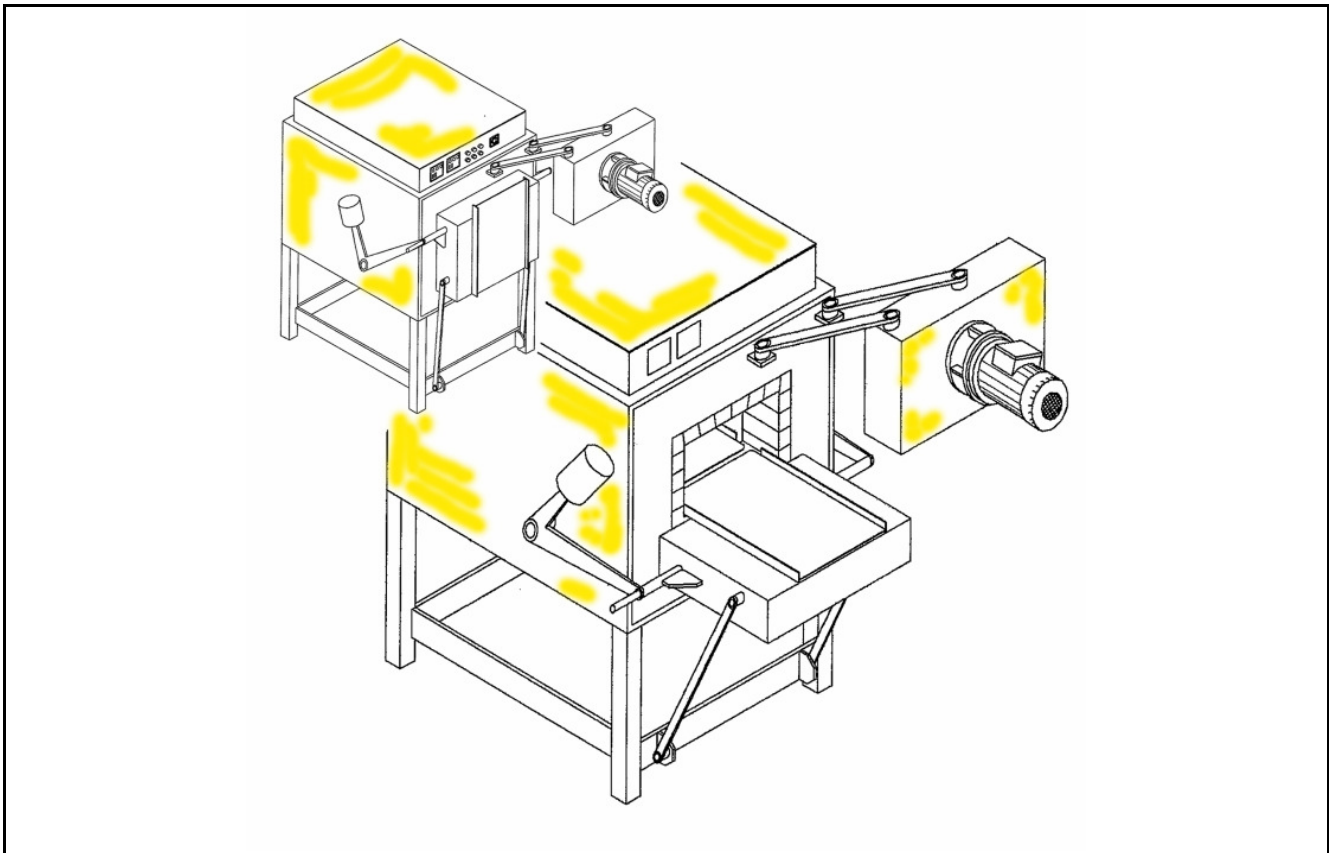

May 2004
anlassof_
0060e

Freilingerstraße 19, A - 4614 Marchtrenk, Austria
Telefon/Fax +43 (0)7243 500 66
Mobil +43 (0)664 590 60 54, +43 (0)664 912 69 23
E-Mail office@ngti.at, ngti@aon.at, Internet www.ngti.at

N.G.T.I.
Nächste Generation
Thermoprozesstechnik
Industriefofensysteme GmbH